

REVISION RECORD				
A	图面新发行	2011-08-15	Jine	OSCAR
B	添加塑料直径	2013-10-17		Oscar

**NOTES:**

**ELECTRICAL:**

- VOLTAGE RATING : 125 VAC RMS.
- CURRENT RATING : 1.5 AMP.
- CONTACT RESISTANCE : 50 MILLIOHMS MAX.
- INSULATION RESISTANCE: 500 MEGOHMS MIN @ 500 VDC.
- DIELECTRIC STRENGTH : 500 VAC RMS 50Hz, 1MIN.

**MECHANICAL:**

- HOUSING MATERIAL : NYLON(PA46)+30%G.F UL94V-0.
- CONTACT MATERIAL : PHOSPHOR BRONZE T=0.35mm (C5210)
- PLATING : GOLD-PLATED IN THE CONTACT AREA
- SHIELD: COPPER ALLOY(OR STEEL ALLOY) 0.20mm THICKNESS
- OPERATING LIFE : 750 CYCLES MIN.
- PCB RETENTION PRE-SOLDER : 1 LB MIN.
- PCB RETENTION POST-SOLDER: 10 LBS MIN.

**ENVIRONMENTAL:**

- STORAGE : -40°C TO +85°C.
- OPERATION: -40°C TO +85°C.
- IR REFLOW PEAK SOLDERING TEMPERATURE:255°C~265°C 5~10 SECONDS.
- ROHS COMPLIANT

FCC PART 68, SUBPART F.  
MATES WITH MODULAR PLUG CONFORMING TO

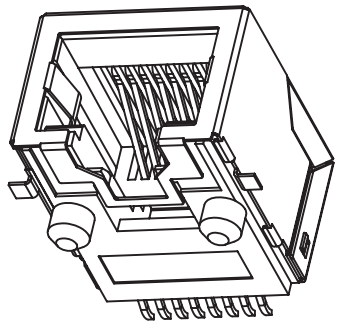
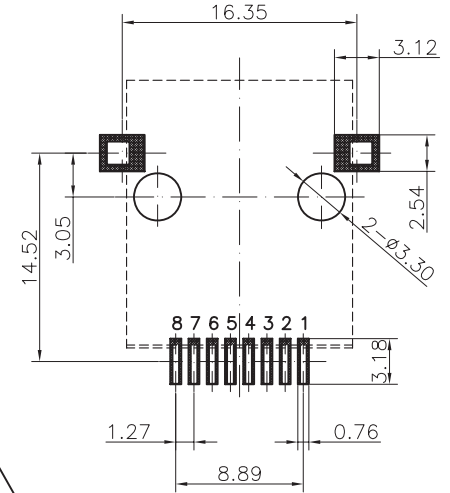
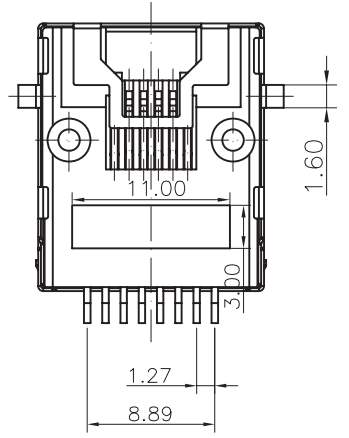
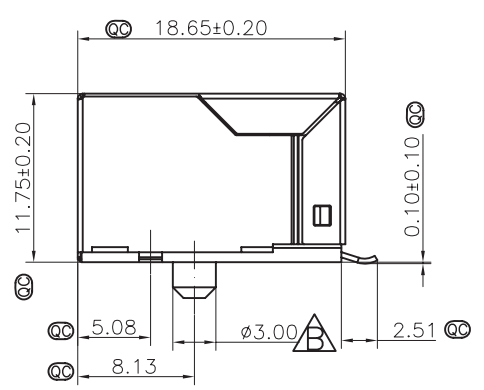
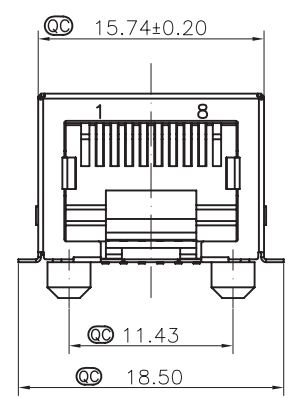

<h1>Coorle库乐科技</h1>	UNIT : mm	Approved By: JP. Gong	
	.xx +/-0.25, .xxx +/-0.13		
Drafted by: JG. CHEN	1X1 SMT RJ45	REV. D	SHEET 1 OF 1
		A4	

-N HUA XIN PERSONNEL WITHOUT WRITTEN AUTHORIZATION FROM SPEED TECH CORP-